

Referencia: 30057

Imbornal sifónico 55x30x70 con fondo

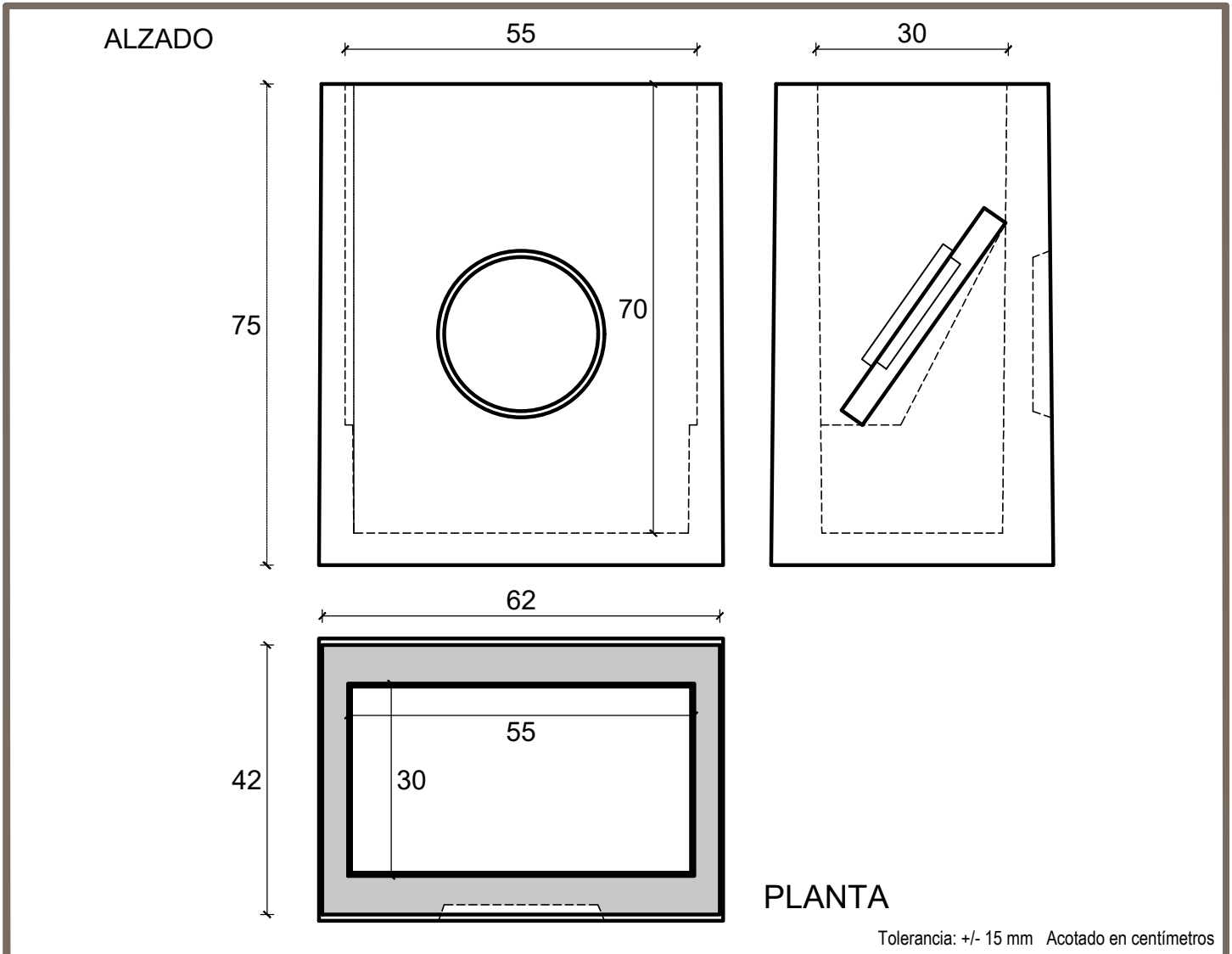

Uso: saneamiento / instalaciones

Medidas	Interior		Exterior		Altura	Ventana	Peso
	Ancho	Largo	Ancho	Largo			
Superior	55	30	62	42	70	1 ventana	265 kg. (aproximado)
Base	53	29	63	44		Ø26	

Hormigón	HM-25
Cemento	CEM II/A-M (P-L) 42,5 R
Áridos	Calizos

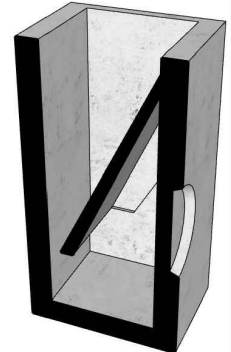
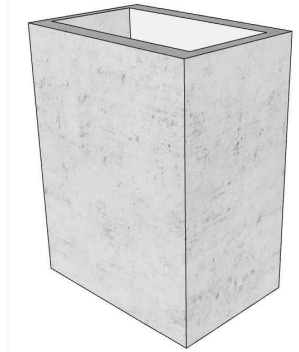
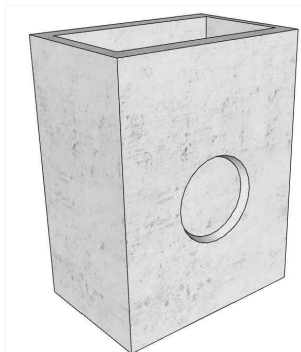

SECCIÓN